



Knowsley Council

## **Advisory note for the care of trees on development sites**

When you receive planning consent it does not include the retention of important trees on the site. In order to assist you in the correct tree protection methods and to help you to comply with your planning conditions, Knowsley Council has produced this short document to give you advice and guidance in caring for trees on development sites.

### **Protective fencing**

#### **Correct position**

The position of this fencing may have already been agreed as part of the planning consent. However, if it has not, it is likely that there will be a planning condition relating to its location which will request the location to be agreed in writing beforehand by the Local Planning Authority. Please contact an Arboricultural Officer on 0151 443 2281/2308 to discuss the matter further before any materials or machinery are brought on site and before development commences.

#### **Correct type**

The type of fencing used for tree protection is detailed below, however it should be a minimum of 2.3 m high which shall use vertical and horizontal scaffolding poles with the uprights driven well into the ground and well braced to resist impact. On to this weldmesh panels (without the use of rubber or concrete feet) should be securely fixed.

**TREE PROTECTIVE FENCING**  
*(BS5837:2005 Trees in Relation to Construction-Recommendations)*

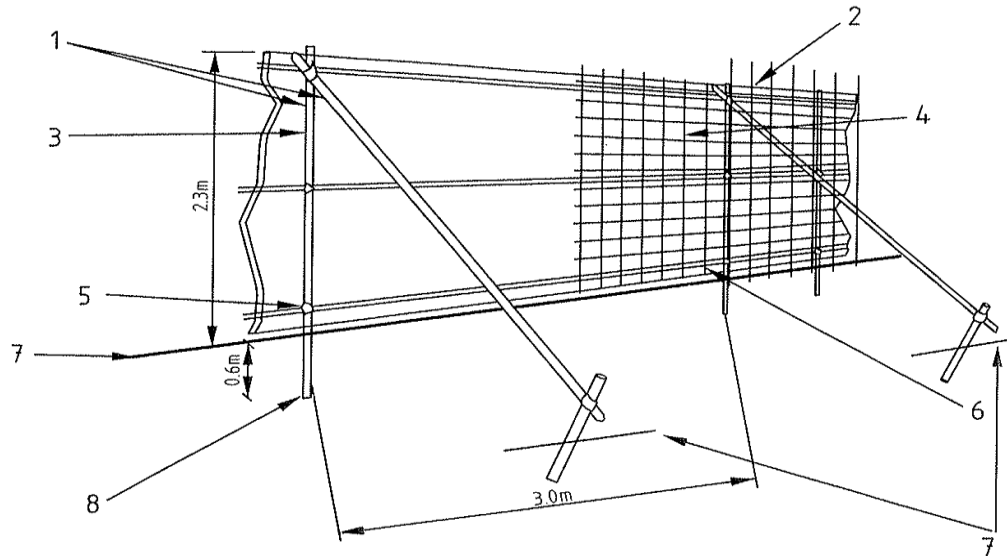

- |  |  |
|--|--|
| 1 Standard scaffold poles  | 5 Standard clamps  |
| 2 Uprights to be driven into the ground  | 6 Wire twisted and secured on inside face of fencing to avoid easy dismantling |
| 3 Panels secured to uprights with wire ties and where necessary standard scaffold clamps | 7 Ground level   |
| 4 Weldmesh wired to the uprights and horizontals   | 8 Approx. 0.6 m driven into the ground   |

## Do's and Don'ts

### Do

- Do ensure that all trees are protected with the correct type of fencing as detailed above and that this remains in position until the development is complete.
- Do advise the site foreman of any problems in relation to trees or difficulties in carrying out your duties because of the presence of trees or the associated protective fencing. Arrangements can then be made for the Local Authority Arboricultural Officer to visit the site to discuss the matter.
- Do continue to respect the trees on site and bear in mind that their presence as a healthy tree cover could be a major selling point on the site.

## **Don't**

- Don't remove the protective fencing without prior agreement from the Local Authority Arboricultural Officer.
- Don't store building materials or equipment around the base of a tree. This can cause compaction, which can kill tree roots.
- Don't pile soil, sand or other materials around the base of a tree. This can cause compaction, which can kill tree roots.
- Don't spill cement, fuel or any other potential pollutants around or near trees.
- Don't light fires or drive vehicles beneath the canopies of the trees on site. Driving cause's compaction and fires can serious damage to the trees stem, branches and roots.

This guidance note is intended to provide general guidance only. If you have any further doubts about what you are required to do to comply with planning conditions relating to trees, please contact the council's Arboricultural Officer at the earliest opportunity on 0151 443 2281/2308.